

# United States Court of Appeals for the Federal Circuit

---

**PROLITEC, INC.,**  
*Appellant*

v.

**SCENTAIR TECHNOLOGIES, INC.,**  
*Appellee*

---

2015-1020

---

Appeal from the United States Patent and Trademark Office, Patent Trial and Appeal Board in No. IPR2013-00179.

---

Decided: December 4, 2015

---

ERIKA ARNER, Finnegan, Henderson, Farabow, Garrett & Dunner, LLP, Reston, VA, argued for appellant. Also represented by J. DEREK MCCORQUINDALE; CORY C. BELL, Boston, MA.

DAVID CLAY HOLLOWAY, Kilpatrick Townsend & Stockton LLP, Atlanta, GA, argued for appellee. Also represented by RENAE WAINWRIGHT; JOSHUA B. POND, Washington, DC; ADAM HOWARD CHARNES, Winston-Salem, NC.

FARHEENA YASMEEN RASHEED, Office of the Solicitor, United States Patent and Trademark Office, Alexandria, VA, argued for intervenor Michelle K. Lee. Also represented by NATHAN K. KELLEY, SCOTT WEIDENFELLER.

---

Before PROST, *Chief Judge*, NEWMAN and TARANTO,  
*Circuit Judges*.

Opinion for the court filed by *Chief Judge* PROST.

Dissenting opinion filed by *Circuit Judge* NEWMAN.

PROST, *Chief Judge*.

This appeal arises from the *inter partes* review (“IPR”) of U.S. Patent No. 7,712,683 (“’683 patent”) owned by Prolitec, Inc. The United States Patent and Trademark Office, Patent Trial and Appeal Board (“Board”) concluded that both of the claims in the ’683 patent were unpatentable as anticipated under 35 U.S.C. § 102 alone and additionally as obvious under 35 U.S.C. § 103. *See ScentAir Techs., Inc. v. Prolitec, Inc.*, IPR2013-00179, Paper No. 60 (PTAB June 26, 2014) (“*Board Decision*”). Prolitec appeals the Board’s determination that the two claims were unpatentable and the Board’s denial of Prolitec’s motion to amend. The Director of the United States Patent and Trademark Office (“Director”) intervenes for the limited purpose of addressing the Board’s regulations and practices regarding motions to amend. For the reasons stated below, we affirm.

#### BACKGROUND

The ’683 patent relates to a cartridge for use with “diffusion devices,” commonly known as air freshener dispensers. *See* ’683 patent col. 1 ll. 56–60. The cartridge contemplated by the ’683 patent with its two major components, a reservoir 114 and a diffusion head 122, are depicted in Figure 9, shown below:

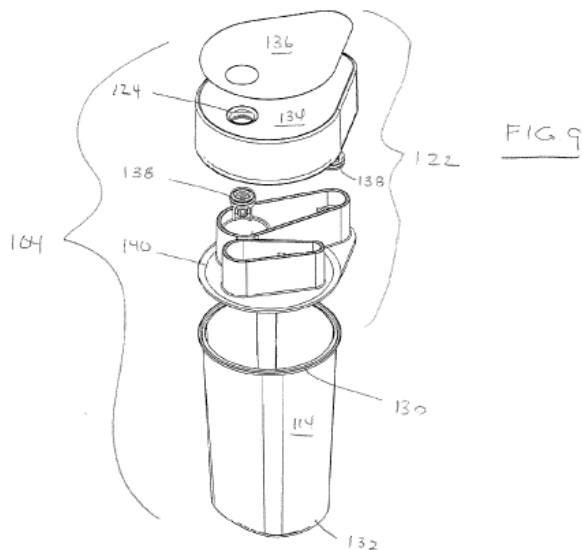

The reservoir contains a liquid to be diffused and a “head space” above the liquid. '683 patent col. 5 ll. 45–57. The diffusion head includes a baffle 140 having an inlet cavity 168 and an outlet cavity 172 detailed in the figure below. *Id.* at col. 6 ll. 38–62. The outlet cavity 172 is further divided by a bulkhead 186 into a first chamber 188 and a second chamber 190. *Id.* The bulkhead and the two chambers trap larger mist particles, which would turn into liquid and flow back to the reservoir. *Id.* at col. 6 l. 63–col. 7 l. 12. The goal is to have mostly the finer mist

FIG. 15

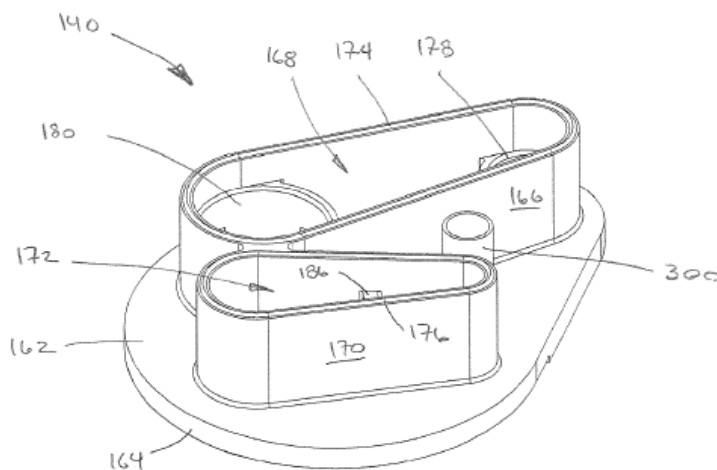

particles exit the cartridge. *Id.*

The diffusion head further includes a venturi assembly, shown below, with an atomizing chamber between the narrow end 238 and the wide end 242. *Id.* col. 9 ll. 26–30.

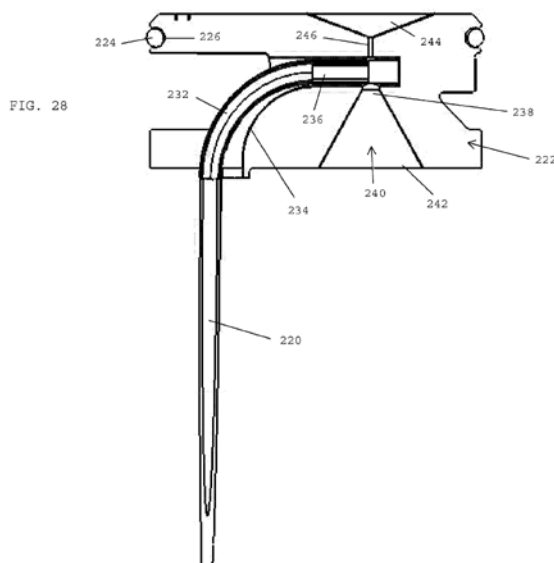

The '683 patent only has two apparatus claims, both are independent. The Board's final written decision on June 26, 2014 found that the two claims of the '683 patent were anticipated by PCT Application No. WO2004/080604A2 ("Benalikhoudja") and obvious over the combination of Benalikhoudja and U.S. Patent No. 7,131,603 ("Sakaida"). The Board also denied Prolitec's motion to amend, concluding that Prolitec did not meet its burden of establishing that it was entitled to the relief requested.

Prolitec appeals from the Board's decision, and the Director intervenes. We have jurisdiction under 28 U.S.C. § 1295(a)(4)(A).

#### DISCUSSION

We review the Board's conclusions of law de novo and its findings of fact for substantial evidence. *See In re*

*Gartside*, 203 F.3d 1305, 1316 (Fed. Cir. 2000). The Supreme Court clarified the standards of review for claim construction in *Teva Pharmaceuticals U.S.A., Inc. v. Sandoz, Inc.*, 135 S. Ct. 831 (2015). Pursuant to *Teva*'s framework and our review of Board determinations, we review the Board's ultimate claim constructions de novo and its underlying factual determinations involving extrinsic evidence for substantial evidence. *See Teva*, 135 S. Ct. at 841–42.

## I

## A

Prolitec first challenges the Board's refusal to narrow the meaning of the claim element "mounted," recited in both patent claims in the context of "a diffusion head mounted to the reservoir." *See* '683 patent col. 16 ll. 1, 35. Prolitec asserted that the claim element should mean "permanently joined." *Board Decision* at 13–14. The Board did not provide a specific construction but relied on the disclosure of the '683 patent and the testimony of Prolitec's expert to reject Prolitec's proposal. *Id.*

On appeal, Prolitec argues that the Board's conclusion was inconsistent with the use of a permanent means of bonding in "every embodiment in the '683 patent" and inconsistent with "[t]he very purpose of the '683 patent" to provide a "disposable cartridge for one-time use" as its expert opined. Appellant's Br. 31–34 (citing J.A. 1553–59, 1563).

Prolitec overstates what the '683 patent describes. The closest description in the '683 patent to Prolitec's "one-time use" argument is a singular mention that "[i]t is also anticipated that all of cartridge 104 *may* be made of a biodegradable material, as it *may* be desirable that the cartridge is configured to be used only one time before being discarded." '683 patent col. 11 ll. 6–9 (emphases added). The problem for Prolitec is that the use of "may"

signifies that the inventors did not intend to limit the patent as Prolitec's expert opined.

Indeed, the very next sentence in the specification shows that the inventors intended for the patent to cover reusable cartridges as well: "It is also anticipated that cartridge 104 could be configured to be returned to a manufacturer or other entity after its planned use to have the cartridge disassembled, cleaned, any worn or damaged parts replaced and then refilled and resealed for use." *See id.* at col. 11 ll. 9-13. This explicit description of disassembling and refilling the cartridge contradicts the opinion of Prolitec's expert. Prolitec's expert cannot rewrite the intrinsic record of the '683 patent to narrow the scope of the patent and the claim element "mounted." *See Phillips v. AWH Corp.*, 415 F.3d 1303, 1318 (Fed. Cir. 2005) (en banc) (explaining that "a court should discount any expert testimony 'that is clearly at odds . . . with the written record of the patent'" (quoting *Key Pharms. v. Hercon Labs. Corp.*, 161 F.3d 709, 716 (Fed. Cir. 1998))).

Moreover, the key passage in the '683 patent relied upon by Prolitec states that "head assembly 604 and reservoir 602 *may* be jointed to each other by heat or ultrasonic welding spin welding, or by use of an adhesive." '683 patent col. 13 ll. 31-33 (emphasis added). As the Board correctly explained, this passage does not limit the possible methods to the examples listed and those examples are not limited to permanent methods of joining. In particular, the Board explained that the use of an adhesive encompasses a non-permanent method of bonding. The Board quoted Prolitec's expert for conceding that bonding by "[a]n adhesive can be permanent or non-permanent." *Board Decision* at 14 (quoting J.A. 1476). This subsidiary factual determination regarding the nature of adhesive bonding was supported by substantial evidence. We discern no error in the Board's rejection of Prolitec's proposal to limit "mounted" to mean "permanently joined."

## B

Prolitec next challenges the Board's construction of "fixed in position," recited in the context of "a conduit including . . . a second end . . . fixed in position with respect to the narrow end" in Claim 1. *See* '683 patent col. 16 ll. 11–15. Prolitec's proposal to construe this claim element to mean "non-adjustable" was rejected by the Board in favor of "stationary." *Board Decision* at 11. The Board noted that Prolitec's only citation to the '683 patent in support of its proposal lacks any discussion of either adjustability or non-adjustability. The Board then rejected Prolitec's expert testimony focusing on the '683 patent's purported contemplation of a single use cartridge as contrary to the '683 patent's express statement that the cartridges may be reused.

On appeal, Prolitec abandons its reliance on the '683 patent's specification. Instead, Prolitec relies solely on its expert's testimony and asserts that allowing for adjustments of the conduit inside the venturi head would not be necessary or desirable because the '683 patent contemplates having the manufacturer setting the conduit in the optimal position.

The Board was again correct. There is nothing in the '683 patent that discusses either allowing or preventing adjustment of the conduit inside the venturi head. Rather, the passage cited by Prolitec before the Board merely states that "second end 236 of tube 220 *is positioned adjacent* a narrow end 238 of a venturi 240." '683 patent col. 9 ll. 26–27 (emphasis added). The Board's claim construction is consistent with the plain meaning of the claim language and the description of positioning the conduit in the specification.

Moreover, as discussed above, the '683 patent describes cartridges that can be disassembled to be reused. *See* '683 patent col. 11 ll. 9-13. Prolitec's expert opinion, premised upon a theory that the '683 patent is limited to

a single-use cartridge, was inconsistent with the intrinsic record of the '683 patent and was properly rejected by the Board. *See Phillips*, 415 F.3d at 1318. We therefore affirm the Board's construction of "fixed in position."

### C

Prolitec finally challenges the Board's construction of "second/secondary chamber," recited in Claim 1 in the context of "the outlet including a second chamber through which the gas within the head space must pass to exit the cartridge" and recited in Claim 2 in a similar context but replacing the word "second" with "secondary." *See* '683 patent col. 16 ll. 20–24, 46–48. Prolitec proposed that the claim element should mean "secondary in reference to the head space, through which the gas must pass after the head space and before exiting the cartridge." *Board Decision* at 14–15 (quoting Prolitec's response). Prolitec argued that the claim language contemplates a system with three chambers: an "initial expansion chamber," a "head space" as a second chamber, and the claimed "secondary chamber" is the third chamber. *Id.* at 15 (quoting Prolitec's response). The Board disagreed with Prolitec, explaining that the claim language recites only two "chambers": an "initial expansion chamber" and a "second/secondary chamber." *Id.* The Board therefore construed the claim element to mean "secondary in reference to the initial expansion chamber." *Id.*

On appeal, Prolitec repeats its contention that the element "head space" is one of three chambers claimed by the '683 patent. Appellant's Br. 36. We cannot agree with this contention. As the Board correctly noted, each claim recites only two "chambers": an "initial expansion chamber" and a "second/secondary chamber." The inventors chose to claim the element "head space" using those precise words, rather than calling it another "chamber." Moreover, there is nothing else in the '683 patent that



would compel an interpretation of “head space” as a “chamber.”

Prolitec further asserts on appeal that the Board’s construction erroneously allows the headspace and the secondary chamber to “collapse into one, such that even just a portion of the head space satisfies the claimed chamber limitation.” *Id.* More specifically, Prolitec faults the Board for finding that a “physical separation” is not needed for the claim element “chamber.” Reply Br. 5–6. These arguments, however, are focused on the meaning of the word “chamber.” Prolitec does not dispute ScentAir’s characterization that the definition of “chamber” was not in dispute before the Board. *See id.* at 6. The dispute before the Board was focused on the basis for the term “second/secondary.” Given what the parties disputed, the Board was justified in stating that each claim, in explicit terms, recites only two “chambers” and then distinguishing the disputed claim element “second/secondary chamber” from the “initial expansion chamber.” We are not persuaded by Prolitec that the Board’s construction was erroneous.

## II

Prolitec appeals the Board’s finding that both claims in the ’683 patent were anticipated by Benalikhoudja. Benalikhoudja is an international patent application also owned by Prolitec. According to Prolitec, Benalikhoudja discloses Prolitec’s earlier product. A representative drawing from Benalikhoudja is reproduced below:

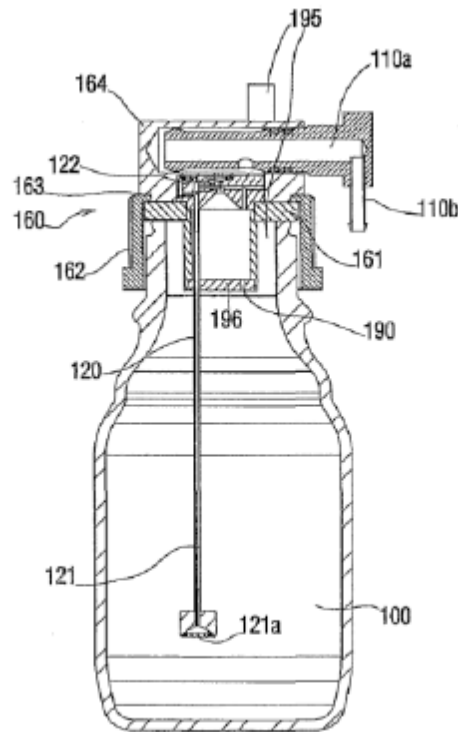

Fig.6

Prolitec argues that Benalikhoudja's fastening of the liquid reservoir by a tamper-proof ring does not satisfy the "mounted" claim element under its proposed construction of "permanently joined." According to Prolitec, Benalikhoudja's tamper-proof ring only signals whether the device has been opened, but does not prevent opening of the device. As discussed above, the '683 patent also does not require a permanent joining between the diffusion head and the reservoir. The '683 patent simply claims "mounted" and describes cartridges that may be configured for one-time use or configured with an ability for remanufacturing. In terms of sealing the respective liquid reservoirs, the '683 patent and Benalikhoudja both contemplate cartridges that are not intended to be opened by consumers, but could be opened outside of normal operation such as during remanufacturing. We are not persuaded by Prolitec's theory in distinguishing Bena-

likhoudja based on the “mounted” claim element in the ’683 patent.

Similar to its “permanently joined” theory, Prolitec argues that Benalikhoudja lacks a diffusion conduit “fixed in position” under its proposed construction of “non-adjustable” because Benalikhoudja teaches instead a micrometer screw for adjusting its nozzle. But the ’683 patent is not limited to devices that affirmatively prevent adjustments of the diffusion conduits and we affirm the Board’s construction of “fixed in position” to mean simply “stationary” as discussed above. Apart from the claim construction, Prolitec does not dispute the Board’s finding that Benalikhoudja’s micrometer screw holds its diffusion nozzle stationary during normal use. *See Board Decision* at 21. We therefore affirm the Board’s finding that Benalikhoudja teaches the ’683 patent’s “fixed in position” claim element.

Prolitec next argues that Benalikhoudja does not teach the ’683 patent’s “second/secondary chamber” because Benalikhoudja lacks a three-chambered system as Prolitec characterizes the ’683 patent to require. Appellant’s Br. 40. Prolitec also faults the Board for finding that the claims “do not require a third chamber.” This is again a claim construction argument which we rejected as discussed above. Prolitec further argues that Benalikhoudja’s release opening 195—identified by the Board as teaching the ’683 patent’s “second/secondary chamber” claim element—is not a “chamber” that is separate from a “head space”: “it is merely the top of the head space.” *Id.* This argument is in large part a dispute on the meaning of “chamber,” which was not raised before the Board as discussed above. Aside from the meaning of “chamber,” Prolitec clearly recognizes that the release opening 195 in Benalikhoudja is a distinct feature from a head space. Indeed, Benalikhoudja labels the release opening 195 separately from the reservoir 100 in which the head space is located. Given that release opening 195

is a feature distinct from a head space, we fail to see any reversible error in the Board's finding that Benalikhoudja's release opening 195 satisfies the '683 patent's "second/secondary chamber" claim element as Prolitec alleges.

Finally, Prolitec argues that the '683 patent requires only two openings at the narrow end of the venturi in contrast to the "*three* openings" "illustrate[d]" in Benalikhoudja. Appellant's Br. 41. The Board found that Benalikhoudja teaches the two openings claimed by the '683 patent and that Benalikhoudja's teaching of a third opening—"nozzle 145 of outside air line 140"—is merely optional. *Board Decision* at 22. The Board therefore concluded that an "optional inclusion" of a feature in the prior art anticipates a claim that excludes the feature." See *Board Decision* at 22 (quoting *Upsher-Smith Labs., Inc. v. PamLab, L.L.C.*, 412 F.3d 1319, 1322 (Fed. Cir. 2005)). The Board's finding and conclusion were both correct. The disputed third opening in Benalikhoudja is explicitly described as optional. J.A. 1349 ("Optionally, the device comprises an outside air inlet duct . . ."); J.A. 1356 ("The venturi 160 *can* also have an outside air line 140 with a nozzle 145 in the nebulization zone 130.") (emphasis added). To counter Benalikhoudja's explicit disclosures, Prolitec relies on its expert to re-characterize Benalikhoudja's third opening as essential, not optional. We are not persuaded by Prolitec's arguments.

We therefore affirm the Board's findings that the two claims in the '683 patent were anticipated by Benalikhoudja. Because we affirm the Board on the anticipation grounds, we do not reach the Board's determination on the obviousness grounds.

### III

Prolitec finally appeals the Board's denial of Prolitec's motion to amend. Prolitec moved to amend the '683 patent by proposing to substitute "permanently joined" for

the element “mounted” in claim 1, thus incorporating its proposed claim construction for the claim element. ScentAir opposed Prolitec’s motion and asserted that a patent by Allred cited during the original prosecution of the ’683 patent teaches permanently joining of a diffusion device. On reply, Prolitec did not dispute that Allred teaches a permanent bonding but asserted that Allred lacks other features purportedly described in the ’683 patent. *See Board Decision* at 29 (quoting Prolitec’s Reply Br. 5). The Board denied Prolitec’s motion to amend, finding that Prolitec failed to demonstrate that the proposed claim “is patentable over, for example, Bena-likhoudja in view of Allred.” *Board Decision* at 30.

On appeal, Prolitec initially argued that the Board’s placing the burden on the patentee to show patentability of the proposed claim amendments was in conflict with the statutes governing IPRs. Subsequent to the parties’ briefing, we issued an opinion in *Microsoft Corp. v. Proxyconn, Inc.*, 789 F.3d 1292 (Fed. Cir. 2015) that resolved this question. Prolitec concedes at oral argument that *Proxyconn* foreclosed Prolitec’s contention that a patentee in an IPR does not bear the burden to show patentability of proposed claim amendments. Oral Arg. at 6:08–6:09, *available at* <http://oralarguments.cafc.uscourts.gov/default.aspx?fl=2015-1020.mp3>.

At oral argument, Prolitec raised two alternative objections to the Board’s decision. First, Prolitec argued that it did not have the burden to establish patentability over prior art references cited in the patent’s original prosecution history because they are not prior art of record in the IPR. *Id.* at 7:21–7:32. Prolitec also argues that the Board failed to consider Prolitec’s arguments in its reply brief in support of its motion to amend. *Id.* at 13:56–14:51. We disagree with Prolitec on both of its arguments.

In *Proxyconn*, we affirmed the Board’s denial of the patentee’s motion to amend because it failed to show that its proposed substitute claims were patentable over “prior art of record”—namely, a reference that the Board used as grounds for instituting review of claims *other* than those sought to be amended. 789 F.3d at 1303–08. We explained that the Board’s interpretation of its regulations in denying the proposed amendment was reasonable under the particular circumstances in *Proxyconn* and was consistent with the United States Patent and Trademark Office’s (“PTO’s”) position expressed in the Board’s informative decision in *Idle Free Systems, Inc. v. Bergstrom, Inc.*, IPR2012–00027, 2013 WL 5947697 (PTAB June 11, 2013). *Proxyconn*, 789 F.3d at 1307. However, we expressly declined to decide in *Proxyconn* whether the PTO’s additional guidance about the patentee’s burden in *Idle Free* also constituted a permissible interpretation of the PTO’s regulations. *Id.* at 1307 n.4. Following our *Proxyconn* decision, the Board issued a “representative decision” providing further guidance on the patentee’s burden on a motion to amend. *See MasterImage 3D, Inc. v. RealD Inc.*, IPR2015-00040 (PTAB July 15, 2015). In particular, the Board stated, among other things, that “prior art of record” includes “any material art in the prosecution history of the patent.” *Id.* at 2.

We conclude that the PTO’s approach is a reasonable one at least in a case, like this one, in which the Board’s denial of the motion to amend rested on a merits assessment of the entire record developed on the motion, not just on the initial motion itself. The Board’s position—that the patentee’s burden on a motion to amend includes the burden to show patentability over prior art from the patent’s original prosecution history—is not in conflict with any statute or regulation. Moreover, it is not unreasonable to require the patentee to meet this burden. The prior art references cited in the original patent’s prosecution history often will be the closest prior art and will

already have been reviewed by the patentee. Evaluating the substitute claims in light of this prior art helps to effectuate the purpose of IPRs to “improve patent quality and limit unnecessary and counterproductive litigation costs.” *Proxyconn*, 789 F.3d at 1308 (quoting H.R. Rep. No. 112–98, pt. 1, at 40 (2011), 2011 U.S.C.C.A.N. 67, 69).<sup>1</sup>

The course of proceedings on the motion to amend in this case demonstrates the reasonableness of the PTO’s position on the scope of prior art the patentee must distinguish. Prolitec knew which proposed claim elements it was relying on to overcome the Board’s invalidity determinations, and in its motion to amend, it asserted that “[n]one of the art of record or other art known to Prolitec discloses, teaches, or suggests a cartridge for use with a liquid diffusion device, including all of these limitations, and having a liquid reservoir that is permanently joined to a diffusion head.” *Board Decision* at 28 (quoting Prolitec’s Mot. to Amend 6). But in the combination of its motion and its reply brief supporting the motion, Prolitec simply failed to support adequately its assertion of pa-

---

<sup>1</sup> The dissent notes that the PTO has suggested changing its rules regarding motions to amend after the briefing was completed in this case and contends that Prolitec did not have the benefit of those changes. Dissent at 6–8. But at least as relevant here, the changes to which the dissent refers were memorialized in *MasterImage 3D*, under which a patent owner does not need to show its claims are patentable over the entire universe of uncited art, but still needs to show its claims are patentable over the prior art of record—which includes art in the prosecution history of the patent. IPR2015-00040 at \*3. The prior art at issue here was undisputedly in the prosecution history of the patent. Thus, the rule change that the dissent cites has no impact in this case.

tentability over Allred (cited in the prosecution history) and Benalikhoudja (the key IPR prior art), even after ScentAir had called attention to Allred in opposing the motion to amend. *See Board Decision* at 29 (citing ScentAir’s Opp. to Motion to Amend at 10–11).

In particular, Prolitec’s argument in its reply brief that the proposed amendment would be patentable over the Allred reference was limited to asserting that Allred fails to anticipate the proposed claim, i.e., that Allred does not teach every single limitation. Prolitec, however, conceded that Allred teaches the very element of “permanently joined” that Prolitec was seeking to add. *See Board Decision* at 29–30 (quoting Prolitec’s Reply Br. 5 (“Allred’s disclosure does include a liquid reservoir that may be welded to an ‘atomizing nozzle’ but the nozzle does not include anything to prevent large liquid particles from escaping the device, such as an outlet cavity having a second opening downstream from a head space.”)).

Given Prolitec’s concession and the Board’s finding that Benalikhoudja anticipates the original claims, Prolitec should have also shown that its amended claim would be patentable over the obviousness combination of Benalikhoudja and Allred. The Board, in fact, specifically asked Prolitec during oral argument whether Prolitec showed that its proposed claim would be non-obvious over, for example, Benalikhoudja in combination with Allred. *See* J.A. 2068 (“The problem is that you also need to show why the claim is not obvious. It doesn’t seem like an argument was made on that ground. If it was, it would have been an argument about the claim is patentable over Benalikhoudja in view of Allred/Poncelet.”). But Prolitec provided no substantive and particularized response to the Board’s direct question, asserting in closing only that “even from an obviousness perspective, the elements still need to be in a combination somewhere, and Prolitec is not aware of such combination.” *See* J.A. 2084.



The record thus shows that the Board considered Prolitec's arguments, and simply rejected them on the merits, considering the full record made on the motion to amend. The Board plainly quoted from Prolitec's reply brief addressing the Allred reference cited in the prosecution history of the '683 patent. *See Board Decision* at 29 (quoting Prolitec's Reply Br. 5). The Board further quoted from Prolitec's arguments made during the oral hearing regarding the prior art reference cited in the prosecution history of the '683 patent. *See id.* (quoting Tr. 68, ll. 19–69, l. 2). We cannot agree with Prolitec's contention that the Board failed to consider Prolitec's arguments in its reply brief. Thus, this case does not present the questions that would be raised by a Board denial of a motion to amend based entirely on procedural or other deficiencies in the initial motion, independently of any consideration or assessment of the full record developed on the motion for what it indicates about the patentability of the proposed substitute claims.

In the circumstances of this case, we also cannot find a denial of procedural rights, such as those granted by the Administrative Procedure Act, based on an insufficient notice or opportunity to respond. For example, as in *Proxyconn*, “this is not a case in which the patentee was taken by surprise by the Board's reliance on an entirely new reference or was not given adequate notice and opportunity to present arguments distinguishing that reference.” *Proxyconn*, 789 F.3d at 1308. The Board simply disagreed with Prolitec's arguments for sufficient reasons on the merits. We discern no reversible error in the Board's denial of Prolitec's motion to amend.

**AFFIRMED**

# United States Court of Appeals for the Federal Circuit

---

PROLITEC, INC.,  
*Appellant*

v.

SCENTAIR TECHNOLOGIES, INC.,  
*Appellee*

---

2015-1020

---

Appeal from the United States Patent and Trademark Office, Patent Trial and Appeal Board in No. IPR2013-00179.

---

NEWMAN, *Circuit Judge*, dissenting.

This appeal is from *inter partes* review of United States Patent No. 7,712,683 (the '683 patent) under the America Invents Act of 2012. Review was requested by ScentAir Technologies, Inc., and proceeded to trial and decision of the Patent Trial and Appeal Board (PTAB), invalidating the patent. This appeal is directed to several aspects of the PTO's and this court's implementation of this new administrative proceeding.

The courts are charged with assuring agency fidelity to law and to legislative purpose. The Supreme Court has stated:

Reviewing courts are not obliged to stand aside and rubberstamp their affirmance of administrative decisions that they deem inconsistent with a statutory mandate or that frustrate the congressional policy underlying a statute. Such review is always properly within the judicial province, and courts would abdicate their responsibility if they did not fully review such administrative decisions.

*N.L.R.B. v. Brown*, 380 U.S. 278, 291–92 (1965); *see also Bowen v. Michigan Acad. of Family Physicians*, 476 U.S. 667, 672 n.3 (1986) (“The responsibility of enforcing the limits of statutory grants of authority is a judicial function; . . . [w]ithout judicial review, statutory limits would be naught but empty words.”) (citation omitted).

Of primary concern is the PTO’s treatment of the statutory provisions for claim amendment in these post-grant proceedings. The panel majority holds that the PTAB properly refused entry of an amendment, although Prolitec complied with all of the statutory and regulatory requirements. The amendment would have narrowed the claims, potentially avoiding a dispositively adverse claim construction. I respectfully dissent from my colleagues’ ratification of this and other departures from the governing statute and the underlying congressional policy.

## A

### ***The PTO erred in refusing to enter Prolitec’s substitute claim 3***

The America Invents Act authorizes limited claim amendment, as follows:

35 U.S.C. § 316(d)(1) In general.— During an inter partes review instituted under this chapter, the patent owner may file 1 motion to amend the patent in 1 or more of the following ways:

- (A) Cancel any challenged patent claims.

- (B) For each challenged claim, propose a reasonable number of substitute claims.

. . . .

- (3) Scope of claims. — An amendment under this subsection may not enlarge the scope of the claims of the patent or introduce new matter.

PTO regulations authorize denial of a claim amendment that complies with the statute, but only when:

- (i) The amendment does not respond to a ground of unpatentability involved in the trial; or
- (ii) The amendment seeks to enlarge the scope of the claims of the patent or introduce new subject matter.

37 C.F.R. § 42.121(a)(2). “Ground of unpatentability” in this regulation refers to the statutory basis of the petition for *inter partes* review, for the regulations require the petitioner to identify “[t]he specific statutory grounds under 35 U.S.C. §§ 102 or 103 on which the challenge to the claim is based and the patents or printed publications relied upon for each ground.” 37 C.F.R. § 42.104(b)(2).

Prolitec moved to amend by replacing claim 1 with claim 3, which replaced the term “mounted” with the term “permanently joined.” The PTAB refused to enter the amendment, and then invalidated claim 1 on the “broadest” interpretation of “mounted” to include other than permanent mounting. Only permanent affixation is described in the specification, and is emphasized as a distinction from Prolitec’s prior device, which is the closest prior art.

When a proposed amendment would resolve a dispositive aspect of claim breadth, refusal to enter the amendment is contrary to both the purpose and the text of the America Invents Act.

The PTO has intervened in this appeal to defend the PTAB's refusal of the amendment. However, entry of a compliant amendment is of statutory right, and patentability of the amended claim is properly determined by the PTAB during the IPR trial, not for the first time at the Federal Circuit.

## B

### ***The PTO's placement of the burden of proof for amended claims is contrary to statute***

I start with the PTO's treatment of the burden of proof, for if the PTO tribunal is to serve as a surrogate for the district courts' determination of patent validity, the same decision-affecting procedural rules should apply in the PTAB as in the district court.

The America Invents Act places the burden of proof on the post-grant petitioner, and provides:

35 U.S.C. § 316(e) Evidentiary standards.—In a post-grant review instituted under this chapter, the petitioner shall have the burden of proving a proposition of unpatentability by a preponderance of the evidence.

That statutory prescription applies whether the “proposition of unpatentability” is for amended or unamended claims. However, the PTAB disregards this statutory requirement by placing on the patentee the burden of proving patentability for a proposed amended claim. The PTAB so held in *Idle Free Systems, Inc. v. Bergstrom, Inc.*, 109 U.S.P.Q.2d 1443, 1459 (PTAB Jan. 7, 2014) (“The burden is not on the petitioner to show unpatentability [of amended claims], but is on the patent owner to show patentable distinction over the prior art of record and also prior art known to the patent owner.”) (citing *Idle Free*, Decision on Motion to Amend Claims, § 42.121 at 7, IPR2012-00027 (PTAB June 11, 2013), Paper No. 26) (emphasis omitted)).

The America Invents Act does not authorize or suggest such a shift in the statutory burden. The PTO, in its Intervenor’s brief, invokes the practice of district court litigation and argues that if the patentee files a motion, it bears the burden of establishing entitlement to grant of the motion. However, this generalization is inapplicable when there are explicit statutory burdens that set a different standard.

The Act requires the PTAB to analyze the patentability of “any new claim added under section 316(d),” 35 U.S.C. § 318(a), again reflecting the statutory directive that the new claim should be added, provided that it qualifies under the statute. The PTAB then determines patentability of the added claim in accordance with the statutory burdens. The statute places the burden of proving invalidity (unpatentability) on the petitioner. As explained by Senator Kyl, “inter partes reexamination is converted into an adjudicative proceeding in which the petitioner, rather than the Office, bears the burden of showing unpatentability.” 137 Cong. Rec. S1360, S1375 (daily ed. Mar. 8, 2011). The Act makes no distinction between original and amended claims in *inter partes* review.

My colleagues on this panel depart from the statute in removing from the petitioner the burden of showing unpatentability of amended claims.

### C

***The preponderance of the evidence is the statutory standard for PTAB validity decisions; judicial review should determine whether the PTAB correctly applied that standard***

The PTAB invalidated Prolitec’s claims by applying the broadest reasonable construction standard, instead of determining the correct claim construction in accordance

with the specification and the prosecution history. Pro-litec argues that its claims, and particularly proposed substitute claim 3, are not invalid when given the correct construction. However, the PTAB reviewed the claims under the broadest reasonable construction standard, and this court reviewed the PTAB decision under the highly deferential substantial evidence standard. With deferential review an incorrect PTAB decision is less likely to be corrected on appeal, contrary to the purpose of the America Invents Act to achieve *correct* determinations of patentability.

The substantial evidence standard is inappropriate in this context. There is no requirement that every administrative decision on every subject must receive deferential review. The standard of review should be attuned to the circumstances. When the America Invents Act assigned to the PTAB the preponderance of the evidence standard for these post-grant procedures, it became inappropriate for the PTAB to give deference to the PTO's prior ruling granting the patent. It also became inappropriate for the PTAB to use the district court's clear and convincing evidence standard. The America Invents Act explicitly states that the PTAB should apply the preponderance standard, illustrating the careful balance in the Act; it is the judicial responsibility to assure that this balance is preserved. 35 U.S.C. § 316(e) (requiring proof of unpatentability by a preponderance of the evidence).

Thus, our review of the PTAB's decision must assure that the preponderance of the evidence standard is met. My colleagues err in applying the substantial evidence standard to America Invents Act post-grant appeals.

#### D

***In the evolving state of PTAB practice, Pro-litec is entitled to the benefit of PTO interpretations and changes in practice***

Prolitec advises that two days after the PTO filed its Intervenor's Brief supporting the PTAB's refusal to accept substitute claim 3, the PTO announced changes with respect to amendment entry. The *Director's Forum: A Blog from USPTO's Leadership: PTAB's Quick-Fixes for AIA Rules Are to Be Implemented Immediately*, available at [http://www.uspto.gov/blog/director/entry/ptab\\_s\\_quick\\_fixes\\_for](http://www.uspto.gov/blog/director/entry/ptab_s_quick_fixes_for) (Mar. 27, 2015), stated that

regarding motions to amend, we are contemplating proposed changes to emphasize that a motion for a substitutionary amendment will always be allowed to come before the Board for consideration (i.e., be "entered"), and for the amendment to result in the issuance ("patenting") of amended claims, a patent owner will not be required to make a prior art representation as to the patentability of the narrowed amended claims beyond the art of record before the Office.

This indicates both a retreat from the PTAB's ruling that Prolitec was required to show patentability over "any other prior art reference that also may teach the very limitation," whether or not of record, PTAB Op. at 30, and an acknowledgement that motions to amend are to be entered as of right. However, the PTO imposed the prior rule on Prolitec, and its brief stated that "the Board did not abuse its discretion by requiring Prolitec to come forth with a showing of patentability of its proposed substitute claim over the prior art known to it . . . ." PTO Br. 28. When this rule change was publicly announced, it seems unfair to punish Prolitec for non-compliance with a rule that had already been discarded by the PTO.

Prolitec was not only denied the benefit of the PTO's change of position, but was also denied the right to amend, although this right was granted by the "quick-fix." Prolitec's motion met all of the requirements, and distinguished not only the references of record, but also the



references cited by ScentAir and references “within the knowledge of Prolitec.” Motion to Amend at 14.

On this appeal, the PTO now concedes that “the patent owner complied with the requirements of rule 42.121.” PTO Br. 21. However, the PTO also argues that the proposed amendment was properly “den[ied] . . . anyway because the patent owner did not adequately show that the new claims are patentable over the prior art **in general.**” *Id.* (citing *Idle Free*, 109 U.S.P.Q.2d at 1456–61). I emphasize “in general,” for such an open-ended expedient has no limits. Indeed, the PTO has also retreated from this position, as the panel majority has recognized.

The panel majority states that on July 15, 2015, the PTAB retreated from that position in *MasterImage 3D, Inc. v. RealD Inc.*, IPR2015-00040 (PTAB July 15, 2015). In *MasterImage 3D*, the PTAB stated that “prior art of record . . . refer[s] to: any material art in the prosecution history of the patent; . . . of record in the current proceeding . . . ; and . . . of record in any other proceeding before the Office involving the patent,” and that “prior art known to the patent owner . . . should be understood as no more than the material prior art that Patent Owner makes of record in the current proceeding pursuant to its duty of candor and good faith to the Office under 37 C.F.R. § 42.11, in light of a Motion to Amend.” *Id.* at 2-3.

My colleagues state that “changes to which the dissent refers were memorialized in *MasterImage 3D.*” Maj. Op. at 15 n.1.<sup>1</sup> If so, the PTAB has an obligation to give

---

<sup>1</sup> The panel majority misapplies the PTAB’s holding in *MasterImage 3D*. First, this opinion is not “precedential” within the PTAB. See PTAB Standard Operating Procedures 2 (Revision 9), Publication of Opinions and

Prolitec the benefit of that change, for the PTO states in its Intervenor's Brief that this is the only remaining ground in support of the PTAB's denial of the motion to amend.

I take note of fresh uncertainty concerning the right to amend, for on November 3, 2015 the following colloquy took place at the argument of another appeal in which the PTO intervened. I inquired of PTO counsel:

Court: So it is the position of the Office that . . . a patent owner has a statutory right to an amendment?

PTO: The patent owner has a statutory right to file what is called a motion to amend . . .

Court: You said to file a motion to amend. Do they have the right to have the motion granted?

PTO: No, Your Honor.

Court: Or only the right to file it?

PTO: Only the right to file a motion.

...

---

Designation of Opinions as Precedential (2014). All other opinions (designated as Informative, Representative, or Routine) are "not binding authority." *Id.* at 3–4. *Idle Free* was designated "Informative;" *MasterImage 3D* has been placed in the newly created (Revision 9) category of "Representative," and does not "memorialize" anything. The Board is not bound to follow *MasterImage 3D* in any later case, nor is any practitioner before the Board able to rely on *MasterImage 3D* as "providing guidance." The PTO has made clear that it only binds itself through "Precedential" opinions. "Informative" decisions are not binding.

Court: So there is no right to amend?

PTO: No, Your honor.

Oral Argument, *Synopsys, Inc. v. Mentor Graphics, Inc.*, No. 2015-1516 (Argument transcript at 24:39–27:24, November 3, 2015, available at <http://oralarguments.cafc.uscourts.gov/default.aspx?fl=2014-1516.mp3>).

I assume that such inconsistency will be clarified. Meanwhile, however, Prolitec is entitled to the benefit of changes “memorialized” by the Board while this case was pending. *Landgraf v. USI Film Prods.*, 511 U.S. 244, 264 (1994) (a court must “apply the law in effect at the time it renders its decision”) (quoting *Bradley v. Sch. Bd. of Richmond*, 416 U.S. 696, 711 (1974)); R. Pierce, Jr., Administrative Law Treatise § 6.7 (“[A]gencies with the power to adjudicate cases can engage in retroactive law-making by replicating the practice of courts . . . [t]he Court has consistently upheld that practice.”).

In view of this error or uncertainty, we should remand to the PTAB for reconsideration of its denial of the amendment.

## E

***The PTAB’s claim construction requires judicial review for correctness as a matter of law, not deferential review as question of fact***

The ’683 invention is an improvement on Prolitec’s own prior device, which required opening the liquid reservoir to refill the container, a messy procedure subject to leaking and spills, inconsistent scent concentration, clogs, and cross-contamination. Prolitec states that the ’683 device solved these problems by using disposable cartridges where the vacuum/suction created by the venturi effect permits sealed containers to be emptied efficiently by the dispersal mechanism, all while avoiding the mess.

The PTAB found anticipation by the Benalikhoudja reference, which is directed to Prolitec's prior device. A finding of anticipation requires that the same invention was previously known and described, not that a claim can be construed so broadly and incorrectly as to embrace a prior art device. The device of the '683 patent is not shown in the prior art; it is not the same as the Benalikhoudja device.

Prolitec appeals the construction of three claim terms, stating that the constructions do not conform to the specification. Prolitec states that these terms were incorrectly broadened so as to reach subject matter that is not within the scope of correctly construed '683 claims.

1.

The PTAB construed the '683 claims as including a two-chambered system as in the prior art, although the specification and embodiments all show a three-chambered system and explain its advantages over the prior art's two chambers. The PTAB, revising the '683 invention to eliminate the third chamber, stated that

claims 1 and 2 require an initial expansion chamber, a head space, and a second/secondary chamber that is secondary in reference to the initial expansion chamber, but not necessarily a separate, third chamber coming after the headspace.

PTAB Op. at 15 (quotations omitted). No reference supports the PTAB's finding that the '683 device did not "necessarily" constitute a third chamber, and the prior art does not show a structure comparable to the head space in the '683 patent. Nonetheless, the PTAB and my colleagues on this panel find that Prolitec's three-chamber device is "anticipated" by the prior art two-chamber device. The PTAB stated:

To the extent Patent Owner means the claims require a second/secondary chamber in addition to

requiring a head space, we agree. But, to the extent that Patent Owner argues that the claims require some level of physical separation between the head space and second/secondary chamber, we disagree.

PTAB Op. at 19. This is not the law of anticipation. Anticipation requires that the same invention was previously known; it is apparent from the specification that the PTAB's analysis is not correct.

## 2.

For the claim element “a diffusion head *mounted* to the reservoir,” the PTAB construed the term “mounted” to mean that the cartridge “may be reused through disassembly, refilling, and reassembly.” PTAB Op. at 13. The PTAB did not permit Prolitec to amend the claim to replace “mounted” with “permanently joined.”

The specification describes the diffusion head as “bonded” to the liquid reservoir, such as by “heat,” “ultrasonic welding,” “spin welding,” or “by use of an adhesive.” ’683 Patent, col. 13 ll. 31–33. The permanence of this attachment pervades the description in the patent. Every embodiment in the specification shows permanent attachment of the cartridge, which cannot be disassembled by the end user without destroying it. Prolitec’s expert testified that:

If one were to attempt to separate the diffusion head from the liquid reservoir, neither part would be able to be reused and the entire cartridge would be destroyed. Thus, the cartridge in the ’683 patent is an integrated unit that cannot be disassembled without destroying the cartridge.

Decl. of Timothy Shedd, IPR2013-00179, Prolitec Ex. 2003, p. 32 (Dec. 13, 2013). The panel majority incorrectly attributes to the expert the position that the car-

tridge can be removably adhered, a theory that is contrary to the entirety of the specification and testimony.

The panel majority further agrees with the PTAB that the Prolitec cartridge is not a single-use cartridge, because the '683 patent suggests that used cartridges be returned to the factory "to have the cartridge disassembled, cleaned, any worn or damaged parts replaced, and then refilled and sealed for use." '683 Patent, col. 11, ll. 9–13. Factory recycling is not contrary to a single-use cartridge in the hands of the consumer. This ruling is incorrect.

### 3.

The PTAB also misconstrued the '683 patent's recitation of "second end of the conduit . . . fixed in position with respect to the narrow end," col. 16, ll. 12–15, as anticipated by the prior art refillable cartridge. This error again illustrates the incorrectness of the practice of construing these claims "broadly," for this broad construction is not supported by either the specification or the prosecution history. Since post-grant procedures are conducted for issued patents, the claims should be construed correctly, as would a district court and as should the Federal Circuit. The PTAB, having construed the claims overly broadly, found them invalid, while depriving the patentee of the statutory right to amend.

The PTAB also erred in separately analyzing each incremental difference from the prior art, whereas it is the claimed combination as a whole whose obviousness must be determined. The PTAB, in its acknowledgement of Prolitec's attempt to substitute narrowed claim 3, disposed of it on this improper analysis:

We understand that Patent Owner maintains that several limitations, which are common to issued claim 1 and proposed claim 3, provide patentable distinctions over the prior art. As we have al-

ready held claim 1 to be unpatentable, these limitations cannot distinguish claim 3 over the prior art.

PTAB Op. at 30. This analysis fails the requirement of 35 U.S.C. § 103 that obviousness is determined on the invention as a whole. This is an error of law, and cannot be endorsed on a “substantial evidence” standard of review.

### *Conclusion*

I support bringing PTAB expertise to bear in a post-grant review system. However, the purpose of post-grant review is not to stack the deck against the patentee, but to achieve a correct and reliable result—for innovative enterprise is founded on the support of a system of patents.

The legislative record shows that Congress was aware that the America Invents Act would apply to issued patents that had previously been examined by PTO procedures, and on which patentees may have relied for investment and commercial activity. Returning the patent to the granting agency, amid complaints that the agency too often granted invalid patents, was a long-debated recourse, intended to rehabilitate the innovation incentive. The America Invents Act reflects a careful balance of the various interests and needs—and it is the judicial obligation to assure that the administrative mechanisms are faithful to the legislative purpose. The court’s rulings today do not meet that obligation. I respectfully dissent.