

NOTE: This disposition is nonprecedential.

**United States Court of Appeals
for the Federal Circuit**

CSP TECHNOLOGIES, INC.,
Plaintiff-Appellant

v.

**SUD-CHEMIE AG, SUD-CHEMIE, INC., AIRSEC
S.A.S., CLARIANT PRODUKTE DEUTSCHLAND
GMBH, CLARIANT CORPORATION, CLARIANT
PRODUCTION (FRANCE) S.A.S.,**
Defendants-Appellees

2015-1124

Appeal from the United States District Court for the
Southern District of Indiana in No. 4:11-cv-00029-RLY-
WGH, Judge Richard L. Young.

Decided: March 22, 2016

JAMES RICHARD NUTTAL, Steptoe & Johnson, LLP,
Chicago, IL, argued for plaintiff-appellant. Also repre-
sented by JOHN LLOYD ABRAMIC, THOMAS ARTHUR
RAMMER, II.

SEAN MICHAEL SULLIVAN, Lee Sullivan Shea & Smith
LLP, Chicago, IL, argued for defendants-appellees. Also

represented by JOHN DAN SMITH, III; PAUL H. BERGHOFF, PAULA FRITSCH, McDonnell, Boehnen, Hulbert & Berghoff, LLP, Chicago, IL.

Before REYNA, MAYER, and CHEN, *Circuit Judges*.

CHEN, *Circuit Judge*.

This appeal arises from a patent-infringement action CSP Technologies, Inc. (CSP) filed against Süd-Chemie AG, Süd-Chemie, Inc., Airsec S.A.S., Clariant Produkte Deutschland GMBH, Clariant Corporation, and Clariant Production (France) S.A.S. (Süd Chemie). The district court construed the claim term “an upper housing portion of the container” in Süd Chemie’s favor, and Süd Chemie sought summary judgment of non-infringement both literally and by equivalents based on this construction. The district court granted summary judgment. CSP appeals the district court’s claim construction (and consequently its summary judgment of non-infringement). Additionally, even if we affirm the district court’s claim construction, CSP appeals the grant of summary judgment of non-infringement by equivalents. We affirm the district court on both grounds.

BACKGROUND

CSP and Süd Chemie are competitors in the business of watertight containers for packaging consumer goods. CSP sued Süd Chemie for infringement of its U.S. Patent No. 7,537,137 (the ’137 patent), which claims a particular watertight container with an attached lid. Claim 1, representative for our purposes, reads in relevant part:

A substantially moisture tight container and lid assembly for storing and packaging moisture-sensitive items comprising:

an assembly with a container and a lid,

a) the lid is attached by a hinge to an upper housing portion of the container, the lid has an outer periphery that extends over at least a portion of the container, the lid is provided with a skirt that extends downwardly therefrom,

b) the container has a container base, and a sidewall extending upwardly from the container base,

...

The '137 patent's specification describes two different types of containers. First, it describes a one-piece container. This container is formed as a single piece, with a lid attached by a hinge. It depicts this type of container in Figure 10:

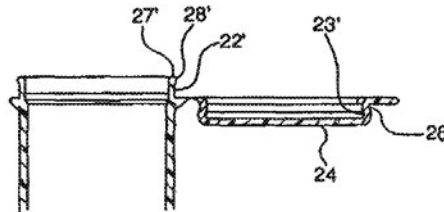
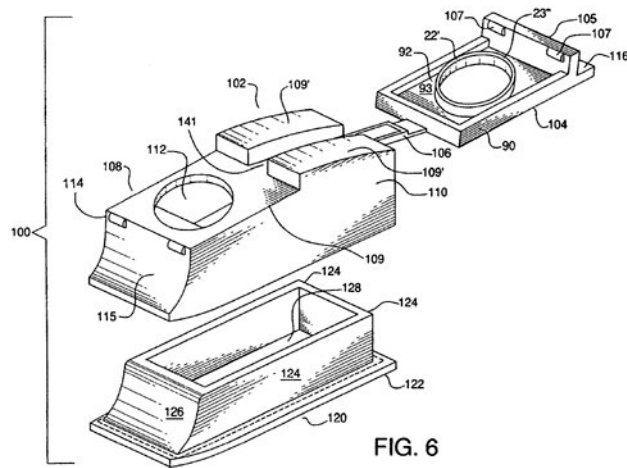

FIG. 10

Second, the patent describes a two-piece container. This container similarly has a lid attached by a hinge, but the top portion of the container to which the lid attaches is separable from the bottom portion of the container. The specification explains that this two-piece container design facilitates pre-loading the container's contents: the contents are first loaded into the container's bottom piece, and then the top piece is snap-fit onto the bottom piece with the contents already inside. The patent's Figure 6 shows this two-piece type of container:



The parties agree that Süd Chemie’s accused product is a one-piece container, not a two-piece one. The only question before us in this appeal is therefore whether a one-piece container infringes the asserted claims, either literally or under the doctrine of equivalents.

The only claim term relevant to the parties’ arguments on appeal is the container’s “upper housing portion.” Below, CSP proposed an ordinary-meaning construction and Süd Chemie proposed the construction: “an upper housing portion of the container that is separate and distinct from the container base.” *CSP Techs., Inc. v. Süd-Chemie AG*, 2013 U.S. Dist. LEXIS 77441, *17 (S.D. Ind. June 3, 2013) (Claim-Construction Order). The parties agree that their claim-construction dispute on this term boils down to a single issue: whether the term excludes one-piece containers from the asserted claims’ scope. Under CSP’s ordinary-meaning construction, the term refers generically to the top portion of the container, whether or not it is separable, and the claims would literally encompass both one-piece and two-piece containers. Under Süd Chemie’s construction the term refers to a separable top piece of the container, excluding one-piece containers from the claims’ literal reach.

The district court began its analysis of this term by determining that the specification did not explicitly define it. The court then turned to an extrinsic dictionary definition of the word “housing,” which defined it as “something that covers or protects” something else. Claim-Construction Order at *19 (quoting Merriam-Webster’s Collegiate Dictionary, 603 (11th ed. 2006)). It found this definition to support a construction where the “upper housing portion” is a separate piece that “covers or protects” the container’s bottom piece. It then turned to the claims themselves, noting that the relevant claim language is divided into two subparts, labeled “a)” and “b).” It found subpart a) to refer to the upper housing portion and subpart b) to refer to the remainder of the container. It therefore found this separation into subparts to imply a physical separation between the upper housing portion and the remainder of the container. Finally, it considered the specification, which uses the term “upper housing portion” consistently and exclusively in the context of the disclosed two-piece embodiment. It inferred from this consistent usage that the patentee intended the term to reference the two-piece embodiment. The district court therefore adopted Süd Chemie’s construction limiting the term to a detachable part found only in the two-piece embodiment. *Id.* at *20.

Concurrent with its claim-construction briefing Süd Chemie had filed briefing requesting summary judgment of non-infringement should the district court grant any of its proposed constructions. The parties fully briefed this summary-judgment motion before the claim-construction order issued, and each party submitted a supplemental brief after the order. *CSP Techs., Inc. v. Süd-Chemie AG*, 2014 U.S. Dist. LEXIS 14687, *8–*9 (S.D. Ind. Feb. 6, 2014). The district court considered this briefing and granted Süd Chemie summary judgment of non-infringement both literally and by equivalents. *Id.* at *18. CSP appeals on two grounds. First, it takes issue with

the district court's construction of "upper housing portion," maintaining that the term's ordinary meaning encompasses one-piece and two-piece containers. If we agree with CSP on this first issue, we must also reverse the district court's summary-judgment order predicated on this construction. Second, even if we affirm the district court's construction, CSP challenges its grant of summary judgment of no infringement under the doctrine of equivalents, arguing that the court improperly found its equivalents arguments barred by the disclosure-dedication and claim-vitiation doctrines.

DISCUSSION

We have jurisdiction under 28 U.S.C. § 1295(a)(1).

We affirm the district court's claim construction. We also find that the district court appropriately applied the disclosure-dedication doctrine to conclude that a two-piece container cannot infringe under the doctrine of equivalents. We therefore need not reach the district court's conclusion that claim vitiation additionally forecloses infringement under the doctrine of equivalents.

I. Claim Construction

"[T]he ultimate issue of the proper construction of a claim should be treated as a question of law." *Teva Pharms. USA, Inc. v. Sandoz, Inc.*, 135 S. Ct. 831, 839 (2015). "[W]hen the district court reviews only evidence intrinsic to the patent (the patent claims and specifications, along with the patent's prosecution history), the judge's determination will amount solely to a determination of law, and the Court of Appeals will review that construction *de novo*." *Id.* at 841. When the district court must go beyond the intrinsic evidence and consider "extrinsic evidence in order to understand, for example, the background science or the meaning of a term in the relevant art during the relevant time period," our review of these factual findings is for clear error. *Id.* We conclude

from our de novo review of the intrinsic record that the patentee unambiguously defined the term at issue.

We begin our analysis with the intrinsic record. *See Phillips v. AWH Corp.*, 415 F.3d 1303, 1317 (Fed. Cir. 2005) (en banc).

The district court correctly took the patentee's decision to divide the relevant portions of its independent claims into subparts labeled "a)" and "b)" to suggest an intention to distinguish the structures claimed in the two subparts. We have taken this approach in prior cases. *See Shire Dev., LLC v. Watson Pharm., Inc.*, 787 F.3d 1359, 1366 (Fed. Cir. 2015); *Default Proof Credit Card Sys., Inc. v. Home Depot U.S.A., Inc.*, 412 F.3d 1291, 1299–300 (Fed. Cir. 2005). We disagree, however, with the district court on which structural elements these subparts describe. Subpart a) ("the lid is attached by a hinge to an upper housing portion of the container, the lid has an outer periphery that extends over at least a portion of the container, the lid is provided with a skirt that extends downwardly therefrom") consists of three independent clauses spliced together with commas. The subject of each clause is "the lid." We therefore find this subpart to refer to the lid. Subpart b) ("the container has a container base, and a sidewall extending upwardly from the container base") describes the container. We find that subpart b) addresses the container. This language implies that the patent's drafter viewed the lid (subpart a)) and container (subpart b)) as distinct. That implication, however, does not inform our determination whether the upper housing portion of the container is separable from the rest of the container.

We next turn to the specification to determine whether the patentee explicitly or implicitly defined the claim term at issue. We agree with the district court that the specification consistently and exclusively uses the term "upper housing" in the context of the two-piece embodi-

ment. *See* '137 Patent at 2:23–31, 3:7–9, 4:7–22, Fig. 14. The patentee's repeated and consistent use of the term "upper housing portion" to describe a separable part of a two-piece container implicitly defines the term to limit it to the two-piece embodiment. *See, e.g., Virnetx, Inc. v. Cisco Sys., Inc.*, 767 F.3d 1308, 1318 (Fed. Cir. 2014); *ICU Med., Inc. v. Alaris Med. Sys., Inc.*, 558 F.3d 1368, 1374–75 (Fed. Cir. 2009). Likewise, the absence of this term in any description of the one-piece embodiment reinforces this implicit definition.

Beyond the claim language and the specification, the intrinsic record also encompasses the patent's prosecution history. Süd Chemie notes that the '137 patent issued from a continuation-in-part application, and that this continuation-in-part application added the term "upper housing portion" in both the claims and the specification. It also explains that during the prosecution of the application that led to the '137 patent, the patentee deleted the term "upper housing portion" from the claims and later added the term back in. It claims that these additions and deletions support its proposed construction of the term but points us to no context supporting this assertion. We see nothing in the prosecution history to suggest that these additions and deletions impart any meaning to the term at issue.

We find that, because the specification consistently and exclusively uses the term "upper housing portion" to refer to two-piece containers, the intrinsic record unambiguously restricts the term to literally encompass only two-piece embodiments. CSP argues that the district court improperly found an extrinsic dictionary definition to trump the intrinsic evidence in arriving at its claim construction. We disagree with that characterization. And even if the district court were to have erred by elevating the extrinsic record above the intrinsic, this error would be harmless because the intrinsic record is con-

sistent with the conclusion the district court drew from the challenged extrinsic evidence.

We therefore affirm the district court's construction of the term, which we view to appropriately limit it to literally encompass only the two-piece embodiment.

II. Infringement by Equivalents

CSP additionally challenges the district court's summary judgment of non-infringement under the doctrine of equivalents. The district court found CSP's assertion of infringement by equivalents to be barred by both the disclosure-dedication and the claim-vitiation doctrines. CSP asserts that each of these findings was erroneous.

When reviewing a grant of summary judgment, we apply the regional circuit's standard of review. *JVC Kenwood Corp. v. Nero, Inc.*, 797 F.3d 1039, 1041 (Fed. Cir. 2015) (citing *Lexion Med., LLC v. Northgate Techs., Inc.*, 641 F.3d 1352, 1358 (Fed. Cir. 2011)). The Seventh Circuit "review[s a] grant of summary judgment de novo, applying the same standards as the district court and viewing the record and all reasonable inferences to be drawn from it in the light most favorable to the non-moving party." *520 S. Mich. Ave. Assocs. v. Unite Here Local 1*, 760 F.3d 708, 718 (7th Cir. 2014) (citing *Griffin v. City of Milwaukee*, 74 F.3d 824, 826–27 (7th Cir. 1996)). "Summary judgment is appropriate only if there is no genuine issue of material fact and the moving party is entitled to judgment as a matter of law." *Id.* (citing *Griffin*, 74 F.3d at 827; Fed. R. Civ. P. 56). "Whether the disclosure-dedication rule prevents a patentee from pursuing a doctrine of equivalents infringement theory is a question of law we review de novo." *SanDisk Corp. v. Kingston Tech. Co.*, 695 F.3d 1348, 1364 (Fed. Cir. 2012).

We begin with the disclosure-dedication doctrine. This doctrine is based on the general notion that "when a patent drafter discloses but declines to claim subject

matter, . . . this action dedicates that unclaimed subject matter to the public.” *Johnson & Johnston Assocs. v. R.E. Serv.*, 285 F.3d 1046, 1054 (Fed. Cir. 2002) (en banc). The disclosure-dedication doctrine bars a patentee from using the doctrine of equivalents to recapture claim scope that it disclosed in the specification but did not literally include in the patent’s claims. *Id.* This doctrine applies even if the patentee later claimed this disclosed subject matter in a continuation application. *Id.* at 1055.

We agree with the district court that the disclosure-dedication doctrine bars CSP’s claim of infringement by equivalents. The patent’s specification discloses two embodiments of CSP’s invention: the two-piece container including a separable upper housing portion and the one-piece container without a separable upper housing portion. But all asserted claims are directed to the embodiment with the separable upper housing portion. The disclosure-dedication doctrine therefore bars CSP from pursuing a theory of infringement by equivalents that would extend its claim scope to encompass this unclaimed embodiment. A later-filed continuation application based on the application that led to the patent in suit reinforces our view that the district court appropriately applied the disclosure-dedication doctrine. This continuation application resulted in a patent, and neither the continuation application as published nor the patent that ultimately issued from it contains the “upper housing portion” claim limitation. *See* U.S. Patent App. Pub. No. 2013/0098934 A1; U.S. Patent No. 8,528,778. The patentee’s decision to claim the upper housing portion in the patent in suit and not to claim it in this continuation patent implies an intent for the two patents to cover different claim scope. The disclosure-dedication doctrine appropriately applies to bar CSP from using the doctrine of equivalents to erase this distinction between its two patents. *See Johnson & Johnston Assocs.*, 285 F.3d at 1055.

CSP argues that the disclosure-dedication doctrine does not apply here because the specification does not explicitly state that the one-piece embodiment is an “alternative” to the two-piece embodiment. As CSP notes, we have held that “the public notice function of patents suggests that before unclaimed subject matter is deemed to have been dedicated to the public, that unclaimed subject matter must have been identified by the patentee as an alternative to a claim limitation.” *Pfizer, Inc. v. Teva Pharms. USA, Inc.*, 429 F.3d 1364, 1379 (Fed. Cir. 2005); accord *SanDisk*, 695 F.3d at 1366–67. But the requirement *Pfizer* and *SanDisk* set out is not as far-reaching as CSP makes it out to be. In *Pfizer*, the plaintiff sought to expand the reach of its claim through the doctrine of equivalents to encompass a product lacking a claimed active compound and instead containing a substitute compound that had similar relevant properties. *Pfizer*, 429 F.3d at 1378. The specification referenced this substitute compound and the class of compounds to which it belonged, but not as an active ingredient in a formulation. *Id.* We found the disclosure-dedication doctrine not to apply there because, although the patentee disclosed the substitute compound it now sought to include in its claims’ scope, it never did so as something that could function as an alternative to the claimed compounds. *Id.* *SanDisk* addressed an unclaimed embodiment disclosed only in a patent that the patent in suit incorporated by reference. There, because the specification of the patent in suit referred to this other patent only in “general terms” rather than pointing to it as containing any alternative to any claimed embodiment, we found the patent in suit’s disclosure not to have dedicated this unclaimed embodiment. *SanDisk*, 695 F.3d at 1366–67. The requirement that the patent must identify the dedicated embodiment as an alternative to a claimed embodiment is therefore not, as CSP suggests, one of form requiring us to identify some language specifically stating that an embodiment is an “alternative.” If that were the case, an artful

drafter could avoid describing embodiments as alternatives and make the patent immune to the disclosure-dedication doctrine. Instead, the requirement is one of substance where we determine from the specification's disclosure whether "one of ordinary skill would have come to the conclusion that the inventor[] ha[s] identified [the unclaimed embodiment] as an alternative to [the claimed embodiment]." *Pfizer*, 429 F.3d at 1379. Here, one of skill in the art would understand from the specification that the inventor contemplated that the one-piece and two-piece designs were alternative ways to construct a container. *E.g.*, '137 patent at 4:4–9 ("In one embodiment, the containers can be formed as a single closed unit, with the hinge joining the lid portion to the container portion. In yet another embodiment, the container assembly comprising the base and upper housing portion can be molded separately."). The existence of a continuation-in-part application claiming the one-piece embodiment further supports our conclusion that the patentee viewed these two embodiments as alternatives.

Because the district court properly concluded that the disclosure-dedication doctrine barred CSP from asserting that the disclosed one-piece embodiment falls within the scope of the asserted claims, CSP cannot succeed in its claim of infringement by equivalents. We therefore do not need to reach the district court's finding that claim vitiation additionally barred a showing of infringement by equivalents.

CONCLUSION

We affirm the district court's construction of "upper housing portion" as limiting the claims' scope to two-piece containers whose upper housing portion is separable from the base. We therefore also affirm the district court's grant of summary judgment of no literal infringement. Because we agree with the district court that the disclosure-dedication doctrine bars CSP's assertion that even

under the district court's construction the doctrine of equivalents expands its claims to capture the one-piece embodiment it disclosed in its specification, we likewise affirm the district court's grant of summary judgment of non-infringement under the doctrine of equivalents.

AFFIRMED

COSTS

No costs.