

NOTE: This disposition is nonprecedential.

**United States Court of Appeals
for the Federal Circuit**

**CAMPBELL SOUP COMPANY, CAMPBELL SALES
COMPANY, TRINITY MANUFACTURING, LLC,**
Appellants

v.

GAMON PLUS, INC.,
Appellee

2018-2099

Appeal from the United States Patent and Trademark
Office, Patent Trial and Appeal Board in No. IPR2017-
00087.

Decided: October 15, 2019

TRACY ZURZOLO QUINN, Holland & Knight LLP, Phila-
delphia, PA, argued for all appellants. Appellants Camp-
bell Soup Company, Campbell Sales Company also
represented by STEVEN E. JEDLINSKI, Chicago, IL.

MARTIN B. PAVANE, Cozen O'Connor, New York, NY, for
appellant Trinity Manufacturing, LLC. Also represented
by DARREN SCOTT MOGIL.

ANDREW L. TIAJOLOFF, Tiajoloff & Kelly LLP, New York, NY, argued for appellee.

Before PROST, *Chief Judge*, NEWMAN and MOORE,
Circuit Judges.

PROST, *Chief Judge*.

Campbell Soup Company, Campbell Sales Company, and Trinity Manufacturing, L.L.C. (collectively, “Campbell”) petitioned for *inter partes* review challenging the validity of claims 1–35 of U.S. Patent No. 8,827,111 (“the ’111 patent”) owned by Gamon Plus, Inc. (“Gamon”). The Patent Trial and Appeal Board (“Board”) instituted review of claims 1–16, 27, 28, and 32–35. In its final written decision, the Board granted patent owner Gamon’s request to cancel claims 1–16 but held that Campbell failed to establish that claims 27, 28, and 32–35 are unpatentable.

We affirm the Board’s determination that claims 27, 28, and 32–35 are not unpatentable over the instituted grounds. We remand, however, for the Board to consider whether non-instituted claims 17–26 and 29–31 are unpatentable and whether claims 27, 28, and 32–35 are unpatentable based on the non-instituted grounds.

I

A

Gamon’s ’111 patent relates generally to “dispenser racks and displays,” and in particular, to “a compact, easy to assemble, easy to load and unload multiple chute dispenser with an integrated display.” ’111 patent col. 1 ll. 15–18. Claim 27, the only instituted independent claim that was not canceled by Gamon, recites:

27. A display rack comprising:

[1] a plurality of generally cylindrical products all having substantially equal diameters and heights;

[2] a pair of laterally spaced vertical panels;

[3] first and second product support structures supported between said panels and defining respectively first and second chutes configured for the products to pass therethrough,

[4] each chute having a respective forward-facing product loading opening in a generally vertically disposed forward side of the display rack and configured to receive the products loaded into the chutes through the forward side, and

[5] a respective dispensing end below the product loading opening such that the cylindrical products when placed in the product loading opening proceed by force of gravity through the associated chute to the dispensing end;

[6] the loading opening and dispensing end of the second chute being situated between the loading opening and dispensing end of the first chute;

[7] wherein the chutes each have a stop structure supported adjacent the respective dispensing end and blocking movement of the products in the chute beyond said stop structure such that the products must be elevated above the stop structure to be removed from the chute; and

[8] wherein the stop structure of the first chute is located at a horizontal distance forward of, and at a vertical distance lower than, the stop structure of the second chute such that when a user removes one of the products against said stop structure of the first chute, the product must be lifted vertically out of the first chute to a withdrawal height wherein the product is at least partly horizontally in front of the stop structure of the second chute;

[9] wherein the horizontal distance that the stop structure of the second chute is offset rearwardly from the stop structure of the first chute is sufficient that one of the products removed by a user from the rack can be replaced on the rack and supported by resting directly on a rearward portion of a forwardmost product in the first chute; and

[10] said panels having a forward edge portion extending vertically adjacent the loading openings of the chutes, the forward edge portion defining a rearward recess therein adjacent the dispensing ends extending a rearward distance toward the stop structure of the second chute at least a diameter of the products and exposing at least a portion of a generally circular end surface of the forwardmost product in the first chute, and

[11] at least a portion of a generally circular end portion of the replaced product when resting thereon.

Id. at claim 27 (limitations identified by bracketed numbers provided by the Board).

Figure 3A is shown below:

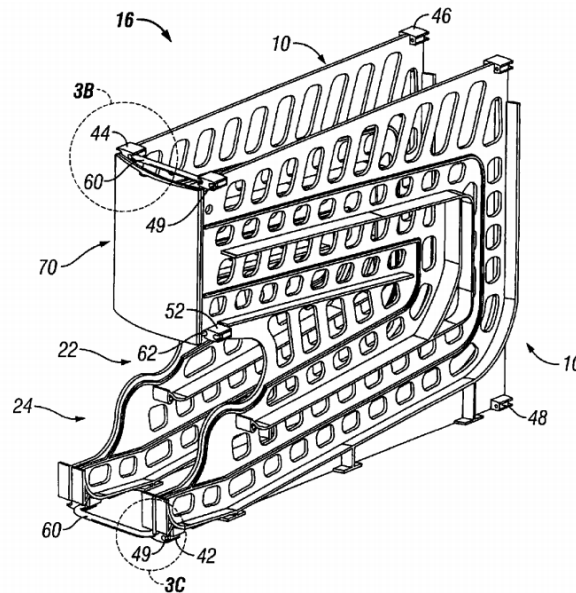

FIG. 3A

The specification explains that “panel 10 includes at least one set of rails 20 which are formed as ribs extending normal to a side 12 of the panel 10 to cooperatively define a plurality of chutes 22, 24 for product which have a boustrophedonic or C-shaped configuration.” *Id.* at col. 4 ll. 19–22. “The chutes 22, 24 are defined between adjacent pairs of panels 10 and are of a width slightly greater than the width of products 90 and which allow the products to be stored and dispensed therefrom.” *Id.* at col. 5 ll. 13–17.

Figure 6A shows “a side view of both a display module with a loading magazine in a loading position.” *Id.* at col. 2 ll. 26–28.

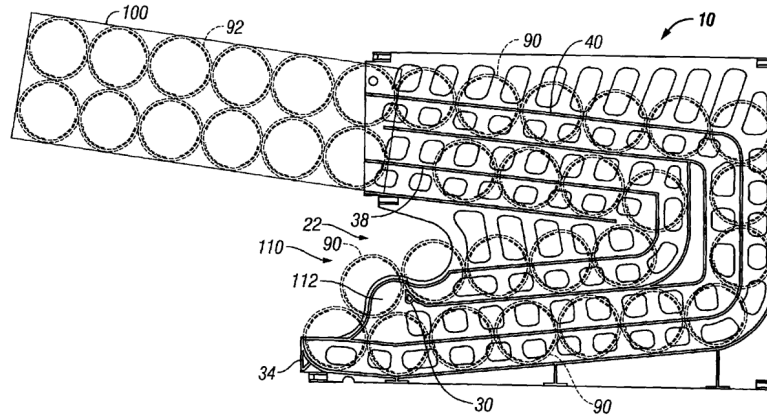

FIG. 6A

“The product 90 is loaded into the chutes 22, 24.” *Id.* at col. 6 ll. 52–53. “The replace stall 110 is further defined as an area in which a product 90 may be replaced if the consumer decides not to purchase.” *Id.* at col. 7 ll. 52–54. Figure 6A illustrates a product in the replace stall, indicating that “a consumer has already replaced a product 90 which was not purchased.” *Id.* at col. 7 ll. 55–56, Fig. 6A.

B

Campbell filed an IPR petition challenging claims 1–35 of the '111 patent based on nine grounds.¹ The Board instituted review on the following three grounds: (1) claims 1–16 as obvious over U.S. Patent Application Publication No. 2004/0011751 (“the ’751 publication”) and U.S. Patent No. 4,105,126 (“Deffner”); (2) claims 27, 28, 33, and 34 as obvious over U.S. Patent No. 2,382,191 (“Weichselbaum”) and European Patent Application Publication No. 0490693 (“Nesso”); and (3) claims 32 and 35 as obvious over Weichselbaum, Nesso, and U.S. Patent No. 3,395,809 (“Mellion”). *Campbell Soup Co. v. Gamon Plus, Inc.*, No. IPR2017-00087, Paper 12, at 52 (P.T.A.B. Apr. 21, 2017) (“*Institution Decision*”). The Board did not institute review of claims 17–26 or 29–31 based on any ground and did not institute review of claims 27, 28, 33, and 34 based on an additional ground of obviousness in view of Weichselbaum, Nesso, and U.S. Patent No. 3,304,141 (“Rogers”) or claims 32 and 35 based on an additional ground of obviousness in view of Weichselbaum, Nesso, Mellion, and Rogers. *See id.*

In its patent owner response, Gamon moved to cancel claims 1–16 and argued that Campbell failed to meet its burden of proving that claims 27, 28, and 32–35 were unpatentable as obvious over the instituted grounds. J.A. 320–21.

In its final written decision, the Board granted Gamon’s request to cancel claims 1–16. *Campbell Soup Co. v. Gamon Plus, Inc.*, No. IPR2017-00087, Paper 75, at 71

¹ The Board identified eighteen unique grounds because many of Campbell’s nine numbered grounds included several alternative combinations of references. *Institution Decision*, at 5–6 & n.3; *see also Campbell Soup Co. v. Gamon Plus, Inc.*, No. IPR2017-00087, Paper 2, at ii–iv (P.T.A.B. Oct. 14, 2016) (“*Petition*”).

(P.T.A.B. May 2, 2018) (“*Final Written Decision*”). The Board also held that Campbell failed to establish by a preponderance of the evidence that claims 27, 28, and 32–35 were unpatentable as obvious based on the instituted grounds. *Id.* at 72.

The Board’s decision rested on four bases, each of which independently supports the conclusion that Campbell failed to establish that claims 27, 28, and 32–35 were unpatentable over the instituted grounds.

First, the Board considered and rejected Campbell’s proposed motivations to combine Weichselbaum and Nesso. *See Final Written Decision*, at 28–37. The Board focused on Campbell’s two specific rationales to modify Weichselbaum to include the second chute of Nesso: (1) to allow for two different canned products to be dispensed; and (2) to increase the capacity of the dispenser using roughly the same amount of shelf space. *Id.* at 30. The Board found neither persuasive, stating that “[u]ltimately, Petitioner presents two very weak reasons based on unstated and unexplained factual assumptions in support of its view that one of ordinary skill in the art would have been prompted to modify Weichselbaum.” *Id.* at 36. The Board elaborated that Campbell “fail[ed] to provide sufficient clarity regarding the specific modifications to Weichselbaum, fail[ed] to provide a sufficient reason with rational underpinning as to why and how one of ordinary skill in the art would have modified Weichselbaum in light of Nesso, and appears, on this record, to engage in an impermissible exercise of hindsight reconstruction to make out a reason to combine the applied references in the manner claimed.” *Id.* at 36–37.

Second, the Board held that the asserted prior art references did not teach limitation [9], which recites “wherein the horizontal distance that the stop structure of the second chute is offset rearwardly from the stop structure of the first chute is sufficient that one of the products

removed by a user from the rack can be replaced on the rack and supported by resting directly on a rearward portion of a forwardmost product in the first chute.” *Id.* at 37–46. The Board began by determining that, without modification, “Weichselbaum’s display and cans do not satisfy the language of limitation [9] because a replaced can would not rest on a rearward portion of a forwardmost product in the first chute.” *Id.* at 39. The Board then analyzed Campbell’s proposed modification of changing the size of the cans of Weichselbaum but found that “the most reasonable interpretation of Weichselbaum is that one would modify the device size in proportion to changes in the can size.” *Id.* at 42. The Board concluded that “just as Weichselbaum, in its unmodified form fails to teach limitation [9] of claim 27, a proportionally scaled down version of Weichselbaum (display and cans) would similarly fail to teach limitation [9].” *Id.*

Third, the Board held that the asserted prior art references did not teach limitations [10] and [11]. *Id.* at 46–55. After analyzing the parties’ competing positions and annotated figures, the Board was “not persuaded that either parties’ position [was] completely correct.” *Id.* at 54. On limitation [10], the Board determined that “[b]ased on the full record, Weichselbaum fails to teach the recited forward edge portion extending vertically adjacent the loading openings of the chutes, defining a rearward recess extending a rearward distance toward the stop structure of the second chute.” *Id.* On limitations [10] and [11], the Board noted that Campbell’s arguments relied on “using smaller cans than those taught by Weichselbaum.” *Id.* at 55. The Board rejected these arguments for the same reasons it gave when addressing limitation [9]—that Campbell “fail[ed] to direct us to a persuasive reason why a person of ordinary skill in the art would have reduced the size of the can, but not the size of the display device, in Weichselbaum.” *Id.*

Fourth and finally, the Board addressed secondary considerations, *id.* at 58–65, and determined that “Patent Owner’s evidence of non-obviousness outweighs Petitioner’s evidence of obviousness,” *id.* at 65.

The Board therefore held that Campbell failed to demonstrate by a preponderance of the evidence that claims 27, 28, and 32–35 were unpatentable as obvious. *Id.* at 65, 72.

Campbell timely appealed. We have jurisdiction pursuant to 28 U.S.C. § 1295(a)(4)(A).

II

A

Obviousness is a question of law based on underlying factual determinations. *Belden Inc. v. Berk-Tek LLC*, 805 F.3d 1064, 1073 (Fed. Cir. 2015). We review the Board’s ultimate obviousness determination de novo and underlying factual findings for substantial evidence. *Harmonic Inc. v. Avid Tech., Inc.*, 815 F.3d 1356, 1363 (Fed. Cir. 2016). Substantial evidence is “more than a mere scintilla” and means “such relevant evidence as a reasonable mind might accept as adequate to support a conclusion.” *Biestek v. Berryhill*, 139 S. Ct. 1148, 1154 (2019) (quoting *Consol. Edison Co. v. NLRB*, 305 U.S. 197, 229 (1938)).

B

We begin with limitation [9] of claim 27, which recites “wherein the horizontal distance that the stop structure of the second chute is offset rearwardly from the stop structure of the first chute is sufficient that one of the products removed by a user from the rack can be replaced on the rack and supported by resting directly on a rearward portion of a forwardmost product in the first chute.” ’111 patent at claim 27. This feature allows the customer to replace a product that they decide not to purchase. *Id.* at col. 7 ll. 52–56, Fig. 6A. The Board determined that this

limitation was not satisfied by Weichselbaum as-is or as-modified.

The Board first found that Weichselbaum without modification did not satisfy limitation [9]. *See Final Written Decision*, at 39 & n.20. (“Weichselbaum’s display and cans do not satisfy the language of limitation [9] because a replaced can would not rest on a rearward portion of a forwardmost product in the first chute.”). The Board provided the following annotated figure of Weichselbaum and explained that “a replaced can (shown in yellow) does not rest directly on a rearward portion of a forwardmost product in the first (lower) chute” and would therefore fall off. *Id.* at 43.

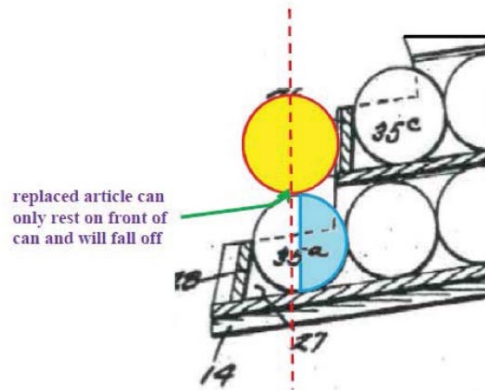

Id. Campbell does not challenge the Board’s determination that Weichselbaum unmodified (i.e., if the size of the device and cans are unchanged) does not satisfy limitation [9].

The Board’s analysis then turned to Campbell’s proposed modification of reducing the size of the cans used in the Weichselbaum dispenser—specifically that “[i]t would be obvious . . . that if slightly smaller cans were used in the Weichselbaum dispenser, the replaced can would rest on the rearward portion of the forwardmost can.” *Id.* at 38 (quoting *Petition*, at 35). The Board acknowledged that it had preliminarily adopted this view in the institution

decision based on the record available at that time. *See id.* at 40 (explaining that in the institution decision the Board “cited to a statement in Weichselbaum that appeared to provide support for Petitioner’s modification to Weichselbaum’s can size. In particular, we commented that ‘Weichselbaum contemplates varying the size of the display to accommodate differently sized cans.’” (quoting *Institution Decision*, at 38 n.16 (citing Weichselbaum at col. 4 ll. 29–32))).

In the final written decision, the Board reconsidered the disclosure in Weichselbaum that “[o]bviously, the device may be made of any desired type of material or in any desired size to accommodate varying sizes of cans to facilitate the dispensing thereof.” Weichselbaum at col. 4 ll. 29–32. With the benefit of the full record developed throughout the IPR proceeding, the Board determined that the disclosure of Weichselbaum is directed to altering the size of the entire display device to accommodate cans of different sizes. *See Final Written Decision*, at 41–42. The Board explained that “the most reasonable interpretation of Weichselbaum is that one would modify the device size in proportion to changes in the can size.” *Id.* at 42. In other words, reducing or increasing the size of the can would result in proportionally reducing or increasing the size of the device. The Board therefore concluded that “just as Weichselbaum, in its unmodified form fails to teach limitation [9] of claim 27, a proportionally scaled down version of Weichselbaum (display and cans) would similarly fail to teach limitation [9].” *Id.*

Campbell argues on appeal that “the dispenser claimed in Weichselbaum—*without any modification to the structure of the device*—is capable of the functionality described in limitation [9] when Weichselbaum is used with cans smaller than those shown for illustrative purposes in its figures.” Appellants’ Br. 31 (emphasis in original). In other words, Campbell argues that limitation [9] is satisfied by reducing the size of the cans but without modifying

size of the Weichselbaum device. Campbell repeatedly argues that “*no modification* of the Weichselbaum *device* is needed.” See Appellants’ Br. 31–34 & n.12 (second emphasis added); Reply Br. 3. But changing the size of the cans used in the Weichselbaum device is a modification of the Weichselbaum reference.

The Board’s determination that modifying the size of the cans used in Weichselbaum would result in a proportional modification to the size of the device is supported by substantial evidence. See *Final Written Decision*, at 39–46. For example, Weichselbaum itself states that “[o]bviously, the device may be made of any desired type of material or in any desired size to accommodate varying sizes of cans to facilitate the dispensing thereof.” Weichselbaum at col. 4 ll. 29–32. This teaching of Weichselbaum is “such relevant evidence as a reasonable mind might accept as adequate to support” the Board’s conclusion that one of ordinary skill in the art following Weichselbaum would use a proportionally smaller display when using a smaller can. See *Biestek*, 139 S. Ct. at 1154 (quoting *Consol. Edison*, 305 U.S. at 229); *Final Written Decision*, at 42.

We do not find any error in the Board changing its understanding of the teachings of Weichselbaum from the institution decision to the final written decision. “[T]he Board is not bound by any findings made in its Institution Decision. At that point, the Board is considering the matter preliminarily without the benefit of a full record. The Board is free to change its view of the merits after further development of the record, and *should do so* if convinced its initial inclinations were wrong.” *Trivascular, Inc. v. Samuels*, 812 F.3d 1056, 1068 (Fed. Cir. 2016). This is exactly what the Board did here, explaining that “[w]e recognize now that our initial determination, made without the benefit of a full trial record, was based on a misunderstanding of Weichselbaum.” *Final Written Decision*, at 42; see also *id.* at 43–44 (“[W]e failed to appreciate the nuances described herein when rendering our Institution Decision.

Nonetheless, we take this opportunity to correct our error.” (footnote omitted)).

C

For the above reasons, we hold that substantial evidence supports the Board’s determination that the prior art does not teach limitation [9] of claim 27. We also conclude that the Board’s findings regarding secondary considerations are supported by substantial evidence. This is sufficient to affirm the Board’s final written decision that claim 27 and claims 28 and 32–35, which depend from claim 27, were not proven to be unpatentable as obvious. We need not reach the remaining bases for the Board’s decision—including the Board’s determination that the prior art also does not teach limitations [10] and [11] of claim 27 or the Board’s determination that there was no motivation to combine Weichselbaum and Nesso.

III

In light of the Supreme Court’s decision in *SAS Institute, Inc. v. Iancu*, 138 S. Ct. 1348 (2018), Campbell challenges the Board’s decision to institute review on some, but not all, of the claims of the ’111 patent and some, but not all, of the grounds raised in its petition. Campbell requests that we remand to the Board so that it may consider the non-instituted claims and grounds. Appellants’ Br. 61–62; Reply Br. 15–17. Gamon contends that Campbell waived its argument for remand pursuant to *SAS* and that the Board’s failure to institute on all challenged claims and grounds was harmless error. Appellee’s Br. 56–65.

On the issue of waiver, Gamon first argues that Campbell waived its right to a remand pursuant to *SAS* for “failure to raise *SAS*-based objections at the PTAB level.” Appellee’s Br. 59–60. However, as Gamon concedes, *SAS* was decided four days *after* the final written decision in this case. Gamon then suggests that Campbell should have filed a request for reconsideration with the Board for

institution of the non-instituted claims and grounds after *SAS* was decided. *Id.* at 60. Gamon cites no authority for the proposition that Campbell was required to file a request for reconsideration based on *SAS*, and we have not required filing a request for reconsideration to preserve a *SAS*-based request for remand. Next, Gamon argues that Campbell waived its request for a remand pursuant to *SAS* by waiting to raise it in its opening brief rather than filing a motion before the merits briefing in this appeal. *Id.* at 61–62. While we have remanded non-instituted claims and grounds pursuant to *SAS* based on requests made in motions, we have not stated that this is the only mechanism to request *SAS*-based remand. Campbell properly preserved this argument by requesting remand pursuant to *SAS* in its opening brief. *See* Appellants’ Br. 61–62.

Gamon also argues that the Board’s failure to institute all of the challenged claims and grounds was harmless error because the final written decision “resolve[d] all issues of the non-instituted grounds or the non-instituted claims.” *See* Appellee’s Br. 62–64. However, the Board did not institute review of claims 17–26 or 29–31 based on any ground, so the Board has not resolved the issue of the patentability of these claims. And while the Board instituted review of claims 27, 28, and 32–35 based on some grounds, it declined to institute review based on all grounds. Following *SAS*, we have remanded to the Board to consider non-instituted claims and grounds. *See, e.g., Adidas AG v. Nike, Inc.*, 894 F.3d 1256, 1257 (Fed. Cir. 2018) (remanding non-instituted grounds for consideration by the Board); *see also BioDelivery Scis. Int’l, Inc. v. Aquestive Therapeutics, Inc.*, 898 F.3d 1205, 1208 (Fed. Cir. 2018) (“Post-*SAS* cases have held that it is appropriate to remand to the PTAB to consider non-instituted claims as well as non-instituted grounds.”) (collecting cases). Remand is appropriate for the Board to address the non-instituted claims and grounds in Campbell’s petition.

IV

Because substantial evidence supports the Board's findings regarding secondary considerations and that limitation [9] of claim 27 is not taught by the prior art, we affirm the Board's determination that claims 27, 28, and 32–35 of the '111 patent are not unpatentable over the instituted grounds. We remand, however, for the Board to consider whether non-instituted claims 17–26 and 29–31 are unpatentable and whether claims 27, 28, 32–35 are unpatentable based on the non-instituted grounds.

AFFIRMED AND REMANDED

COSTS

Costs to Gamon.